



ASSO ..... pag. 26

BIG..... pag. 30

    BIG-ED/EC..... pag. 35

    BIG-KD/KC..... pag. 36

    BIG-PC ..... pag. 37

DOUBLE ..... pag. 38

INDUSTRIAL ..... pag. 42

GRUPPI DI ALIMENTAZIONE ..... pag. 46



Linea e Design tradizionale  
Tecnicamente adeguato alle classiche richieste di mercato  
Diverse tipologie per coprire tutte le esigenze di progettazione

*Traditional Line and Design  
Technically suited for classic market requests  
Different typologies to cover all design requirements*

- Struttura:** Corpo realizzato in pressofusione di alluminio a basso contenuto di rame, con alettature di raffreddamento posteriori.
- Verniciatura:** A polveri epossidiche colore grigio RAL7035, previo trattamento di fosfocromatazione del grezzo. Resistente agli agenti atmosferici ed alle nebbie saline.
- Staffa di fissaggio:** Realizzata in acciaio zincato e verniciata di colore grigio. Sistema goniometrico di regolazione dell'inclinazione.
- Riflettore:**
- SIMMETRICO ad emissione diffondente, realizzato in alluminio martellato purissimo 99,85% brillantato ed ossidato anodicamente.
  - ASSIMMETRICO ad emissione diffondente, realizzato in alluminio martellato purissimo 99,85% brillantato ed ossidato anodicamente.
- Vetro:** Piano temperato spess. 5 mm con serigrafia di colore grigio. Resistente agli urti ed agli shock termici.
- Accesso:** Al vano ottico ed accessori tramite il vetro incernierato al corpo e fissato con ganci in estruso di alluminio, a pressione sul vetro, verniciati di colore grigio.
- Guarnizioni:** Al silicone perimetrali al corpo.
- Viterie:** Esterne in acciaio inossidabile, interne in acciaio zincato.
- Portalampada:** In ceramica tipo RX7S, E40 o K12S
- Gruppo di alimentazione:** Incorporato su piastra zincata per modello LUX150/400 ed esterno al proiettore per modello LUX1000/2000.
- Cavo:** A doppio isolamento al silicone tipo FG4G4
- Componenti elettrici:** Di prima scelta e rigorosamente a marchio di qualità IMQ, ENEC o equivalenti.



CE

Classe I	
Classe II	

IP66

- Structure:** Body made in die cast low copper content aluminium, with rear cooling fins
- Painting:** gray colored epoxy powder RAL7035, by means of phospho-chromate treatment of the raw material. Resists atmospheric agents and salt spray mists.
- Holding bracket:** Made in galvanized steel and painted gray. Adjustment of inclination with protractor system.
- Reflectors:**
- SYMMETRICAL with diffused emission, made in 99,85% pure hammered aluminium, glossed and oxidised anodically.
  - ASSYMMETRICAL with diffused emission, made in 99,85% pure hammered aluminium, glossed and oxidised anodically.
- Glass:** Tempered surface 5 mm thick with gray screen printing. Resistant to blows and thermal shocks.
- Access:** To optical and accessory area through the glass pane hinged to the body and attached with hooks in extruded aluminum, press-fitted to the glass, painted gray.
- Seals:** In silicone bordering the body.
- Screws:** External in stainless steel, internal in galvanized steel.
- Light holder:** Ceramic, type RX7S, E40 or K12S
- Power supply group:** Built in to the galvanized plate for model LUX 150/400 and external to the floodlight for model LUX1000/2000.
- Cable:** Double insulation in silicone type FG4G4
- Electrical components:** first quality and strictly with IMQ, ENEC or equivalent quality-marking.

**Normative di riferimento**

Marchatura CE  
EN 60598-1  
EN 60598-2-3  
Direttive Europee 2006/95/CE e 2004/108/CEE  
Gradi di protezione secondo EN 60529  
Norma sull'inquinamento luminoso UNI 10819  
Leggi Regionali in materia di inquinamento luminoso

**Reference standards**

CE marking  
EN 60598-1  
EN 60598-2-3  
European Directives 2006/95/CE and 2004/108/CEE  
Protection rating pursuant to EN 60529  
Light pollution standard UNI 10819

**Cablaggi**

Classe I: Con componenti elettrici montati su piastra in acciaio zincato, cablati e rifasati con cavo a doppio isolamento al silicone FG4G4. Carcassa e componenti attivi con impianto di messa a terra.

Classe II: Gruppo di alimentazione compatto con reattore resinato e altri componenti integrati in un involucro in materiale isolante omologato classe II. Collegamenti alla lampada con cavo a doppio isolamento al silicone FG4G4.

**Wiring**

*Class I: With electrical components assembled on galvanized steel plate, wired and phase corrected with double insulated cable in silicone FG4G4. Housing and active components with grounding system.*

*Class II: Compact power supply group with resin reactor and other integrated components in a case in class II-approved insulating material. Connections to the light with double insulated cable in silicone FG4G4.*

**Applicazioni**

- Piccoli e grandi impianti sportivi
- Campi da tennis, Calcio a 5
- Palestre
- Aree industriali
- Aree commerciali e parcheggi
- Parchi e monumenti
- Illuminazione di facciate
- Svincoli stradali ed autostradali
- Rotatorie
- Porti, Aeroporti
- Incroci stradali

**Applications**

- Small and large sports centers
- Tennis courts, 5-person soccer
- Gyms
- Industrial areas
- Business centers and parking lots
- Parks and monuments
- Facade illumination
- Street and highway exits
- Rotary circles
- Ports, Airports
- Street intersections

Installazione LUX150-S - Area di servizio Prenestina Sud



Installazione LUX400-A - Maranello





pag. 6

LUX 150-S



pag. 6

LUX 150-A



pag. 8

LUX 1000-S



pag. 8

LUX 1000-A



pag. 9

LUX 2000-A



pag. 7

LUX 400-S



pag. 7

LUX 400-A

# LUX 150 S-A

## Simmetrico - Asimmetrico

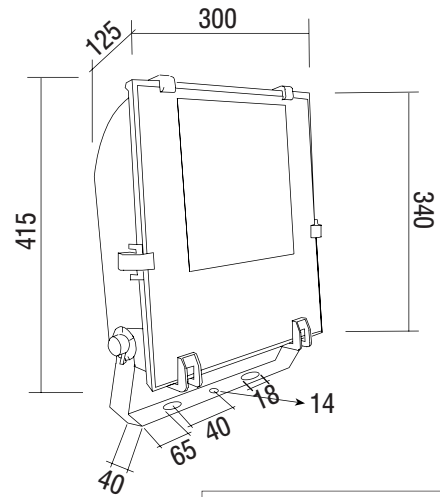

Simmetrico 0,102 m<sup>2</sup>

Asimmetrico 0,042 m<sup>2</sup>

LUX 150 S-A



classe 1 • class 1

Codice	W	Lamp	p/lamp	Kg
LUX150S/A SAP701	70	SAP-T	RX7s	5
LUX150S/A SAP1501	150	SAP-T	RX7s	6
LUX150S/A JM701	70	JM-T	RX7s	5
LUX150S/A JM1501	150	JM-T	RX7s	6

classe 2 • class 2

Codice	W	Lamp	p/lamp	Kg
LUX150S/A SAP702	70	SAP-T	RX7s	5
LUX150S/A SAP1502	150	SAP-T	RX7s	6
LUX150S/A JM702	70	JM-T	RX7s	5
LUX150S/A JM1502	150	JM-T	RX7s	6

su richiesta

- Fusibile
- Colori RAL

on require

- Fuse
- RAL colors

Sistema goniometrico di regolazione dell'inclinazione  
Protractor system for adjustment of inclination



Doppio attacco RX7S  
Double RX7S attachment

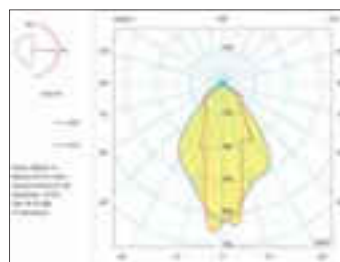

LUX150-S SAP150w

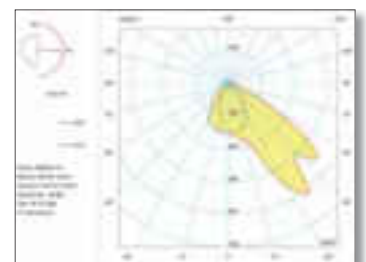

LUX150-A SAP150w

# LUX 400 S-A

## Simmetrico - Asimmetrico

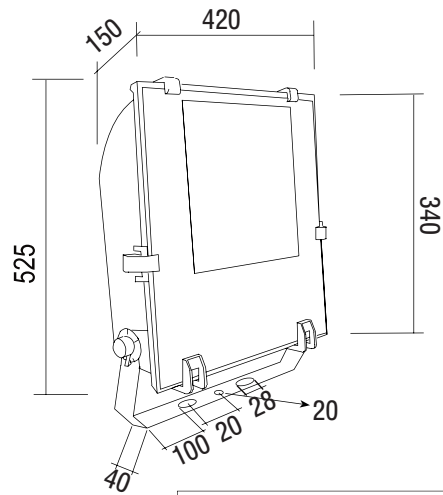

Simmetrico  $0,182 \text{ m}^2$

Asimmetrico  $0,065 \text{ m}^2$



classe 1 • class 1

Codice	W	Lamp	p/lamp	Kg
LUX400S/A SAP2501	250	SAP-T	E40	9,5
LUX400S/A SAP4001	400	SAP-T	E40	10,5
LUX400S/A JM2501	250	JM-T	E40	8,5
LUX400S/A JM4001	400	JM-T	E40	9,5

classe 2 • class 2

Codice	W	Lamp	p/lamp	Kg
LUX400S/A SAP2502	250	SAP-T	E40	9,5
LUX400S/A SAP4002	400	SAP-T	E40	10,5
LUX400S/A JM2502	250	JM-T	E40	8,5
LUX400S/A JM4002	400	JM-T	E40	9,5

su richiesta

- Fusibile
- Colori RAL

on require

- Fuse
- RAL colors

Sistema goniometrico di regolazione dell'inclinazione  
Protractor system for adjustment of inclination

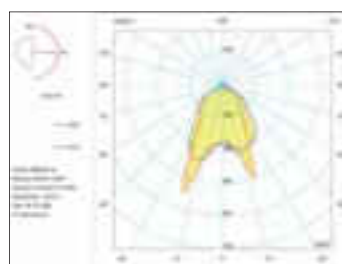

LUX400-S JM400w

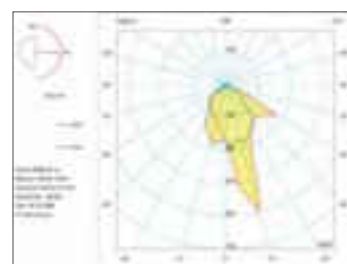

LUX400-A JM250w

LUX 400 S-A

# LUX 1000 S-A

Simmetrico - Asimmetrico

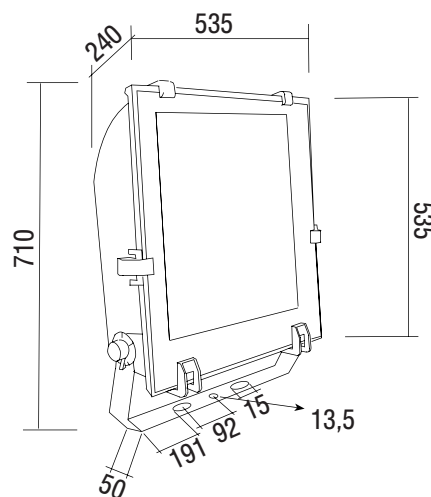

Simmetrico  $0,286 \text{ m}^2$

Asimmetrico  $0,128 \text{ m}^2$

CABLAGGIO CON BOX (vedi pag. 48)  
WIRING WITH BOX (see page 48)

Vano porta accenditore  
Ignition compartment



Sistema goniometrico di regolazione dell'inclinazione  
Protractor system for adjustment of inclination



classe 1 • c/acc

Codice	W	Lamp	p/lamp	Kg
LUX1000S/A SAP6001a	600	6,2A SAP	E40	12
LUX1000S/A SAP10001a	1000	10,3 SAP	E40	12
LUX1000S/A JM10001a	1000	8,2A JM	E40	12
LUX1000S/A JM10001a	1000	9,5A JM	E40	12

classe 1 • s/acc

Codice	W	Lamp	p/lamp	Kg
LUX1000S/A SAP6001	600	6,2A SAP	E40	12
LUX1000S/A SAP10001	1000	10,3 SAP	E40	12
LUX1000S/A JM10001	1000	8,2A JM	E40	12
LUX1000S/A JM10001	1000	9,5A JM	E40	12

su richiesta

- Fusibile  
- Colori RAL

on require

- Fuse  
- RAL colors

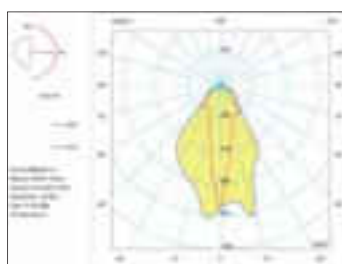

LUX1000-S JM1000w

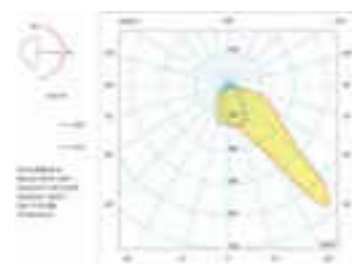

LUX1000-A JM1000w

LUX 1000 S-A

# LUX 2000 A

**Asimmetrico**

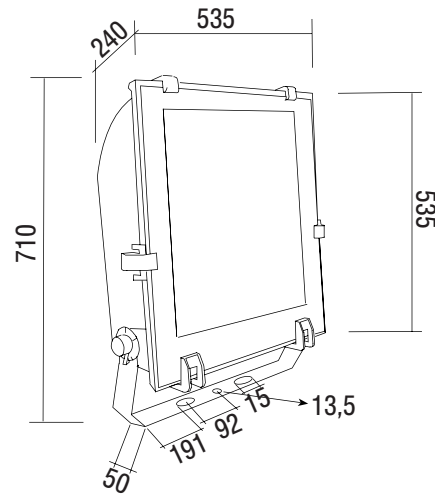

Simmetrico 0,286 m<sup>2</sup>

Asimmetrico 0,128 m<sup>2</sup>

CABLAGGIO CON BOX (vedi pag. 48)  
WIRING WITH BOX (see page 48)

Vano porta accenditore  
Ignition compartment

classe 1 • c/acc

Codice	W	Lamp	p/lamp	Kg
LUX2000A JM20001a	2000	10,3A JM	K12s7	12
LUX2000A JM20001a	2000	16,5A JM	K12s7	12



classe 1 • s/acc

Codice	W	Lamp	p/lamp	Kg
LUX2000A JM20001	2000	10,3A JM	K12s7	12
LUX2000A JM20001	2000	16,5A JM	K12s7	12

Sistema goniometrico di regolazione dell'inclinazione  
Protractor system for adjustment of inclination



su richiesta

- Fusibile
- Colori RAL

on require

- Fuse
- RAL colors



Doppio attacco K12s7  
K12s7 double attachment

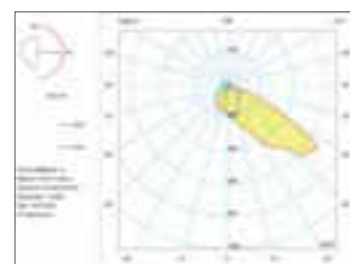

LUX2000A JM2000w

LUX 2000 A



Linea e Design tradizionale  
Tecnicamente adeguato alle classiche richieste di mercato  
Diverse tipologie per coprire tutte le esigenze di progettazione

*Traditional Line and Design  
Technically suited for classic market requests  
Different typologies to cover all design requirements*

- Struttura:** Corpo realizzato in pressofusione di alluminio a basso contenuto di rame, con alettature di raffreddamento posteriori.
- Verniciatura:** A polveri epossidiche colore nero, previo trattamento di fosfocromatazione del grezzo. Resistente agli agenti atmosferici ed alle nebbie saline.
- Staffa di fissaggio:** Realizzata in acciaio zincato e verniciata di colore nero. Sistema goniometrico di regolazione dell'inclinazione.
- Riflettore:**
- SIMMETRICO ad emissione diffondente, realizzato in alluminio martellato purissimo 99,85% brillantato ed ossidato anodicamente.
  - ASIMMETRICO ad emissione diffondente, realizzato in alluminio martellato purissimo 99,85% brillantato ed ossidato anodicamente.
  - PARABOLICO ad emissione concentrante realizzato in alluminio speculare purissimo 99,85% brillantato e ossidato anodicamente.
- Vetro:** Piano temperato spess. 5 mm con serigrafia di colore nero. Resistente agli urti ed agli shock termici.
- Accesso:** Al vano ottico ed accessori tramite il vetro incernierato al corpo e fissato con ganci in estruso di alluminio, a pressione sul vetro, verniciati di colore nero.
- Guarnizioni:** Al silicone perimetrali al corpo.
- Viterie:** Esterne in acciaio inossidabile, interne in acciaio zincato.
- Portalampada:** In ceramica tipo E40, FC2 o K12S
- Gruppo di alimentazione:** Incorporato su piastra zincata per modello FOX150/400 ed esterno al proiettore per modello FOX1000/1000 A2.
- Cavo:** A doppio isolamento al silicone tipo FG4G4
- Componenti elettrici:** Di prima scelta e rigorosamente a marchio di qualità IMQ, ENEC o equivalenti.

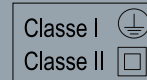

- Structure:** Body made in die cast low copper content aluminium, with rear cooling fins.
- Painting:** black colored epoxy powder, by means of phospho-chromate treatment of the raw material. Resists atmospheric agents and salt spray mists.
- Holding bracket:** Made in galvanized steel and painted black. Adjustment of inclination with protractor system.
- Reflector:**
- SYMMETRICAL with diffused emission, made in 99,85% pure hammered aluminium, glossed and oxidised anodically.
  - ASYMMETRICAL with diffused emission, made in 99,85% pure hammered aluminium, glossed and oxidised anodically.
  - PARABOLIC with concentrated emission made in 99,85% pure mirrored aluminium, glossed and anodically oxidized.
- Glass:** Tempered surface 5 mm thick with gray screen printing. Resistant to blows and thermal shocks.
- Access:** To optical and accessory area through the glass pane hinged to the body and attached with hooks in extruded aluminium, press-fitted to the glass, painted gray.
- Seals:** In silicone bordering the body.
- Screws:** External in stainless steel, internal in galvanized steel.
- Light holder:** Ceramic, type E40, FC2 or K12S
- Power supply group:** Built in to the galvanized plate for model FOX 150/400 and external to the floodlight for model FOX1000/1000A2.
- Cable:** Double insulation in silicone type FG4G4
- Electrical components:** first quality and strictly with IMQ, ENEC or equivalent quality-marking.

**normative di riferimento**

Marcatatura CE  
EN 60598-1  
EN 60598-2-3  
Direttive Europee 2006/95/CE e 2004/108/CEE  
Gradi di protezione secondo EN 60529  
Norma sull'inquinamento luminoso UNI 10819  
Leggi Regionali in materia di inquinamento luminoso

**reference standards**

CE marking  
EN 60598-1  
EN 60598-2-3  
European Directives 2006/95/CE and 2004/108/CEE  
Protection rating pursuant to EN 60529  
Light pollution standard UNI 10819

**Cablaggi**

Classe I: Con componenti elettrici montati su piastra in acciaio zincato, cablati e rifasati con cavo a doppio isolamento al silicone FG4G4. Carcassa e componenti attivi con impianto di messa a terra.

Classe II: Gruppo di alimentazione compatto con reattore resinato e altri componenti integrati in un involucro in materiale isolante omologato classe II. Collegamenti alla lampada con cavo a doppio isolamento al silicone FG4G4.

**wiring**

*Class I: With electrical components assembled on galvanized steel plate, wired and phase corrected with double insulated cable in silicone FG4G4. Housing and active components with grounding system.*

*Class II: Compact power supply group with resin reactor and other integrated components in a case in class II-approved insulating material. Connections to the light with double insulated cable in silicone FG4G4.*

**Applicazioni**

- Piccoli e grandi impianti sportivi
- Campi da tennis, Calcio a 5
- Palestre
- Aree industriali
- Aree commerciali e parcheggi
- Parchi e monumenti
- Illuminazione di facciate
- Svincoli stradali ed autostradali
- Rotatorie
- Porti, Aeroporti
- Incroci stradali

**Applications**

- Small and large sports centers
- Tennis courts, 5-person soccer
- Gyms
- Industrial areas
- Business centers and parking lots
- Parks and monuments
- Facade illumination
- Street and highway exits
- Rotary circles
- Ports, Airports
- Street intersections

Installazione FOX1000-A2 - Modena



Installazione FOX 400-S - Modena



Installazione FOX 400-P - Olbia



**Campo da tennis • Tennis courts**

FOX 400 A - JM 400 w

Lamp. : HQI-T 400 w 45.000 Lm

H : 9 m

**Risultati • Results**

Illuminamento orizzontale: **300 lux medio**

Luminanza media: **38.5 cd/mq**

Uniformità: **83%**

Inquinamento: **0%**

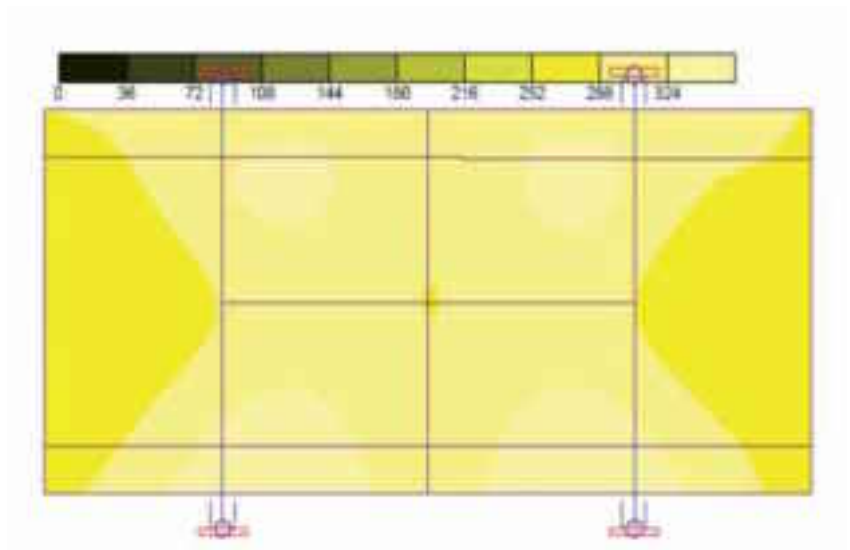
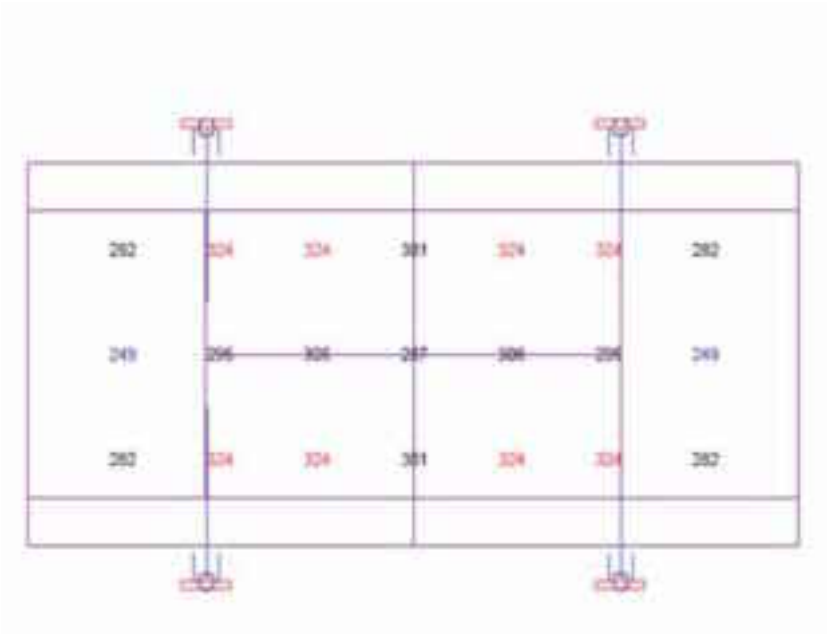
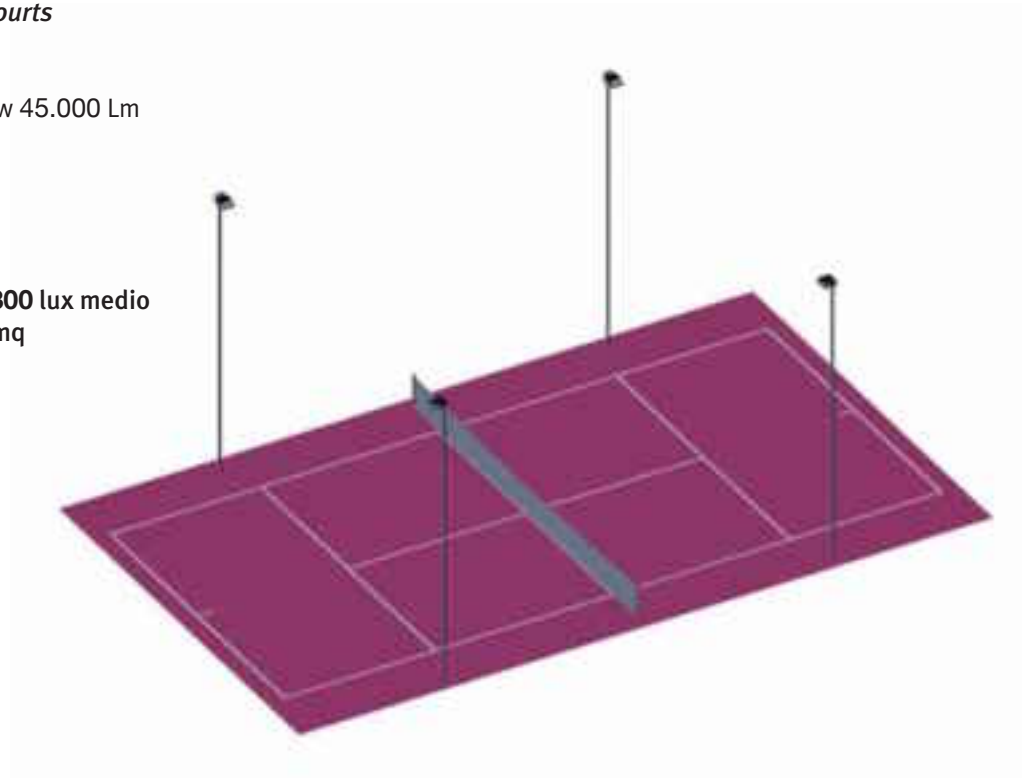



# FOX 150 S-A

## Simmetrico - Asimmetrico

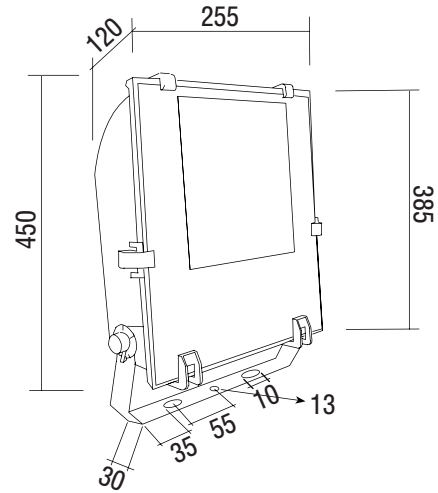

*Simmetrico* 0,10 m<sup>2</sup>

*Asimmetrico* 0,047 m<sup>2</sup>



classe 1 • class 1

Codice	W	Lamp	p/lamp	Kg
FOX150S/A SAP701	70	SAP-T	RX7s	5
FOX150S/A SAP1501	150	SAP-T	RX7s	6
FOX150S/A JM701	70	JM-T	RX7s	5
FOX150S/A JM1501	150	JM-T	RX7s	6

classe 2 • class 2

Codice	W	Lamp	p/lamp	Kg
FOX150S/A SAP702	70	SAP-T	RX7s	5
FOX150S/A SAP1502	150	SAP-T	RX7s	6
FOX150S/A JM702	70	JM-T	RX7s	5
FOX150S/A JM1502	150	JM-T	RX7s	6

su richiesta

- Fusibile
- Colori RAL

on require

- Fuse
- RAL colors

Sistema goniometrico di regolazione dell'inclinazione  
Protractor system for adjustment of inclination



Doppio attacco K12s7  
K12s7 double attachment

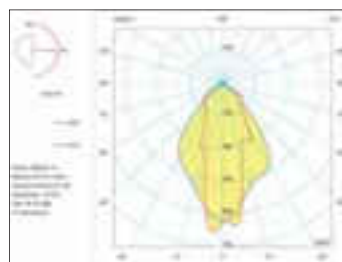

FOX150-S SAP150w

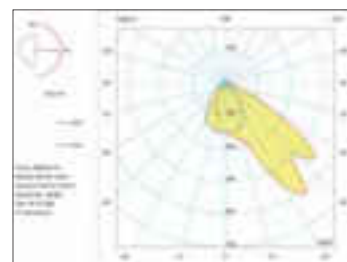

FOX150-A SAP150w

FOX 150 S-A

# FOX 400 S-A

Simmetrico - Asimmetrico

FOX 400 S-A

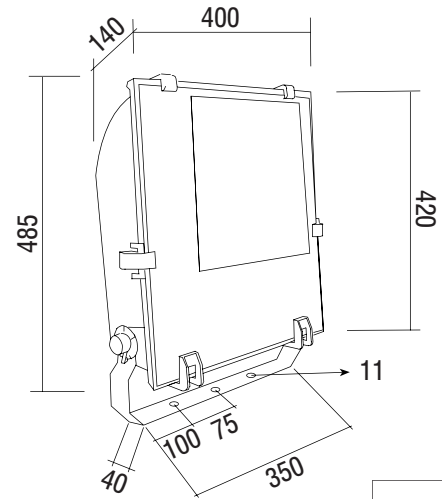

0,065 m<sup>2</sup>



classe 1 • class 1

Codice	W	Lamp	p/lamp	Kg
FOX400S/ASAP2501	250	SAP-T	E40	9,5
FOX400S/ASAP4001	400	SAP-T	E40	10,5
FOX400S/AJM2501	250	JM-T	E40	8,5
FOX400S/AJM4001	400	JM-T	E40	9,5

classe 2 • class 2

Codice	W	Lamp	p/lamp	Kg
FOX400S/ASAP2502	250	SAP-T	E40	9,5
FOX400S/ASAP4002	400	SAP-T	E40	10,5
FOX400S/AJM2502	250	JM-T	E40	8,5
FOX400S/AJM4002	400	JM-T	E40	9,5

su richiesta

- Fusibile
- Colori RAL

on require

- Fuse
- RAL colors

Sistema goniometrico di regolazione dell'inclinazione

Protractor system for adjustment of inclination

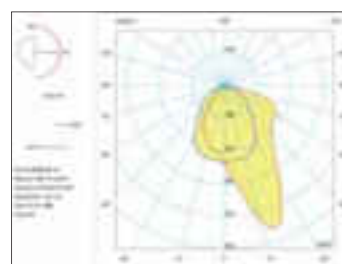

FOX400-S JM400w

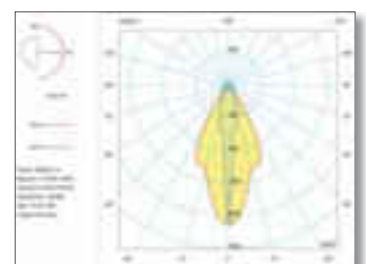

FOX400-A SAP400w

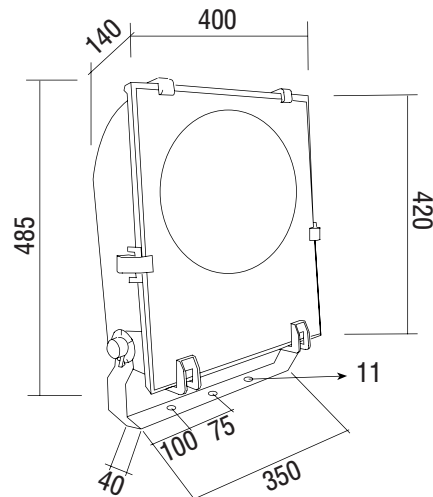

Asimmetrico 0,165 m<sup>2</sup>

**classe 1 • class 1**

Codice	W	Lamp	p/lamp	Kg
FOX400PSAP2501	250	SAP	FC2	9,5
FOX400PSAP4001	400	SAP	FC2	10,5
FOX400PJM2501	250	JM	FC2	8,5
FOX400PJM4001	400	JM	FC2	9,5

**classe 2 • class 2**

Codice	W	Lamp	p/lamp	Kg
FOX400PSAP2502	250	SAP	FC2	9,5
FOX400PSAP4002	400	SAP	FC2	10,5
FOX400PJM2502	250	JM	FC2	8,5
FOX400PJM4002	400	JM	FC2	9,5

**su richiesta**

- Fusibile
- Colori RAL

**on require**

- Fuse
- RAL colors

Sistema goniometrico di regolazione dell'inclinazione  
*Protractor system for adjustment of inclination*



Portalampada FC2  
*Lampholder type FC2*

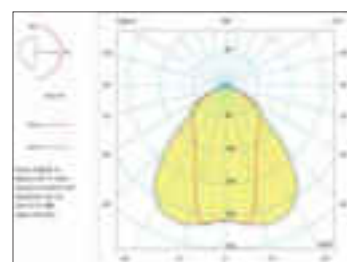

FOX400-P JM 400 W

# FOX 1000 S-A

Simmetrico - Asimmetrico

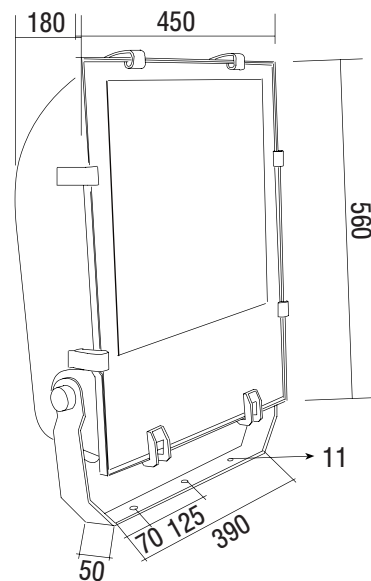

CABLAGGIO CON BOX (vedi pag. 48)  
WIRING WITH BOX (see page 48)

0,25 m<sup>2</sup>

FOX 1000 S-A

classe 1 • c/acc

Codice	W	Lamp	p/lamp	Kg
FOX1000S/A SAP6001	600	SAP-T	E40	11
FOX1000S/ASAP10001	1000	SAP-T	E40	11
FOX1000S/AJM10001	1000	JM-T	E40	11

classe 1 • s/acc

Codice	W	Lamp	p/lamp	Kg
FOX1000S/ASAP6001	600	SAP-T	E40	11
FOX1000S/ASAP10001	1000	SAP-T	E40	11
FOX1000S/AJM10001	1000	JM-T	E40	11

Sistema goniometrico di regolazione dell'inclinazione  
Protractor system for adjustment of inclination



su richiesta

- Fusibile  
- Colori RAL

on require

- Fuse  
- RAL colors

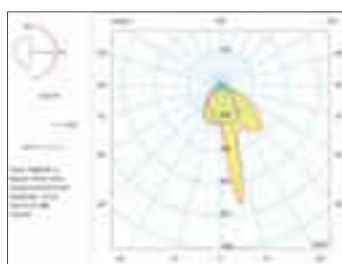

FOX1000S JM1000w

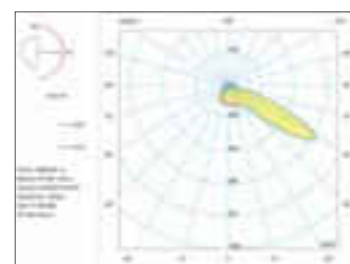

FOX1000A SAP1000w

# FOX 1000 A2

Asimmetrico 55°

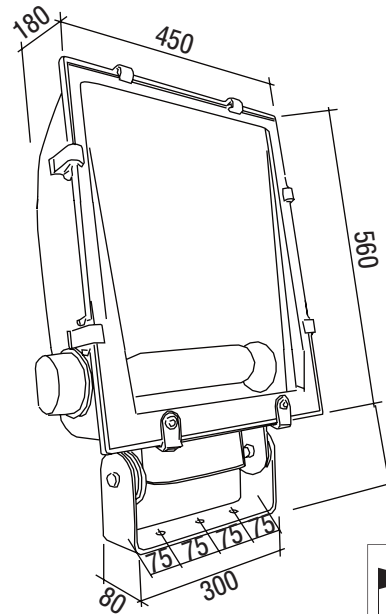

CABLAGGIO CON BOX (vedi pag. 48)  
WIRING WITH BOX (see page 48)

classe 1 • c/acc	Codice	W	Lamp	p/lamp	Kg
	FOX1000A2SAP6001A	600	SAP-T	E40	13,5
	FOX1000A2SAP10001A	1000	SAP-T	E40	13,5
	FOX1000A2JM10001A	1000	JM-T	E40	13,5
	FOX1000A2JM10001AK	1000	JM	K12s7	13,5
	FOX1000A2SAP4001A	400	SAP-T	E40	13,5

classe 1 • s/acc	Codice	W	Lamp	p/lamp	Kg
	FOX1000A2SAP6001	600	SAP-T	E40	13,5
	FOX1000A2SAP10001	1000	SAP-T	E40	13,5
	FOX1000A2JM10001	1000	JM-T	E40	13,5
	FOX1000A2JM10001K	1000	JM	K12s7	13,5
	FOX1000A2SAP4001	400	SAP-T	E40	13,5

Sistema goniometrico di regolazione dell'inclinazione  
Protractor system for adjustment of inclination



**su richiesta**  
- Fusibile  
- Colori RAL

**on require**  
- Fuse  
- RAL colors

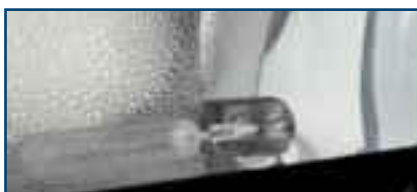

Doppio attacco K12s7  
K12s Double attachment

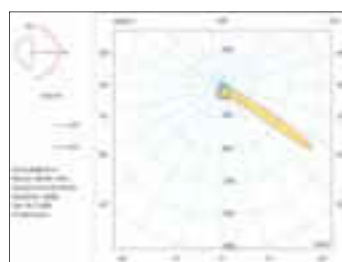

FOX1000A2 SAP400w

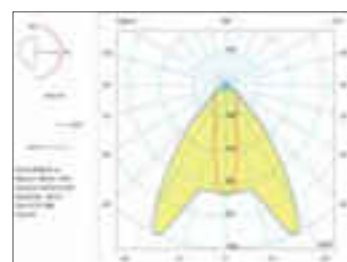

FOX1000A2 SAP1000w

FOX 1000 A2



Imbutito in acciaio Inox AISI 316 con alimentazione in cassetta esterna IP66 fissata al proiettore.

Linea e Design tradizionale.

Tecnicamente adeguato alle classiche richieste di mercato.  
Diverse tipologie per coprire tutte le esigenze di progettazione.

*Deep drawn in AISI 316 stainless steel with power in IP66 external box attached to floodlight.*

*Traditional Line and Design.*

*Technically suited for classic market requests.*

*Different typologies to cover all design requirements.*

- Struttura: Corpo realizzato in imbutitura di lamiera di acciaio inossidabile AISI 316 spessore min. 0,8 mm.
- Staffa di fissaggio: Realizzata in acciaio inossidabile AISI 316 saldata posteriormente al corpo con inclinazione di 6°.
- Riflettore: • SIMMETRICO ad emissione diffondente, realizzato in alluminio martellato purissimo 99,85% brillantato ed ossidato anodicamente.  
• ASIMMETRICO ad emissione diffondente, realizzato in alluminio martellato purissimo 99,85% brillantato ed ossidato anodicamente.
- Vetro: Piano temperato spess. 5 mm, fissato al corpo con quattro angolari e con collante al silicone antimuffa per tutto il perimetro a garantire la tenuta IP. Resistente agli urti ed agli shock termici.
- Viterie: Esterne ed Interne in acciaio inossidabile.
- Portalampada: In ceramica tipo E40 o E27.
- Supporto a Tappo: Realizzato in materiale plastico nylon caricato del 30% di fibra di vetro, fissato sulla fiancata del proiettore e asportabile con 1/3 di giro senza l'utilizzo di utensili, per una facile manutenzione alla lampada. Sistema di regolazione del fuoco lampada.
- Gruppo di alimentazione: Esterno in BOX di alimentazione Classe II. Fissato sulla testata laterale del corpo tramite piastra in acciaio inox AISI 316.
- Dotazioni: PG13.5 antistrappo in ottone nichelato. Cavo elettrico 2x1,5mmq tipo FTG10(O)M1 per il collegamento dalla cassetta di alimentazione al portalampada del proiettore.
- Componenti elettrici: Di prima scelta e rigorosamente a marchio di qualità IMQ, ENEC o equivalenti.

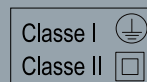

IP 66



- Structure: Body made in deep-drawn AISI 316 stainless steel sheets min. thickness 0.8 mm*
- Holding bracket: Made in AISI 316 stainless steel rear welded to the body with 6° inclination*
- Reflector: • SYMMETRICAL with diffused emission, made in 99,85% pure hammered aluminium, glossed and oxidised anodically.  
• ASYMMETRICAL with diffused emission, made in 99,85% pure hammered aluminium, glossed and oxidised anodically.*
- Glass: Tempered surface 5 mm thick, attached to body with four corner mounts and with anti-mold silicon adhesive for the entire border to guarantee IP seal. Resistant to blows and thermal shocks.*
- Screws: External and internal in stainless steel.*
- Light holder: Ceramic, type E40 or E27.*
- Cap support: Made in plastic nylon material loaded with 30% fiberglass, attached to the side of the floodlight and removable with 1/3 turn without need of tools, for easy maintenance of the light. Adjustment system for light focus.*
- Power supply group: External in Class II power BOX. Attached to the side body head by means of an AISI 316 stainless steel plate.*
- Equipment: PG13.5 jerk-safe in nickel-plated brass. Electrical cable 2x1,5 sq mm type FTG10(O)M1 for connection from the power box to the light holder of the floodlight.*
- Electrical components: first quality and strictly with IMQ, ENEC or equivalent quality-marking.*

normative di riferimento

Marcatura CE  
EN 60598-1  
EN 60598-2-3  
Direttive Europee 2006/95/CE e 2004/108/CEE  
Gradi di protezione secondo EN 60529  
Norma sull'inquinamento luminoso UNI 10819  
Leggi Regionali in materia di inquinamento luminoso

reference standards

CE marking  
EN 60598-1  
EN 60598-2-3  
European Directives 2006/95/CE and 2004/108/CEE  
Protection rating pursuant to EN 60529  
Light pollution standard UNI 10819

cablaggi

Classe I: Con componenti elettrici montati su piastra in acciaio zincato, cablati e rifasati con cavo a doppio isolamento al silicone FG4G4. Carcassa e componenti attivi con impianto di messa a terra.

Classe II: Gruppo di alimentazione montato su piastra isolata con sezionatore di linea per classe II. Collegamenti alla lampada con cavo a doppio isolamento al silicone FG4G4.

wiring

*Class I: With electrical components assembled on galvanized steel plate, wired and phase corrected with double insulated cable in silicone FG4G4. Housing and active components with grounding system.*

*Class II: Compact power supply group with resin reactor and other integrated components in a case in class II-approved insulating material. Connections to the light with double insulated cable in silicone FG4G4.*

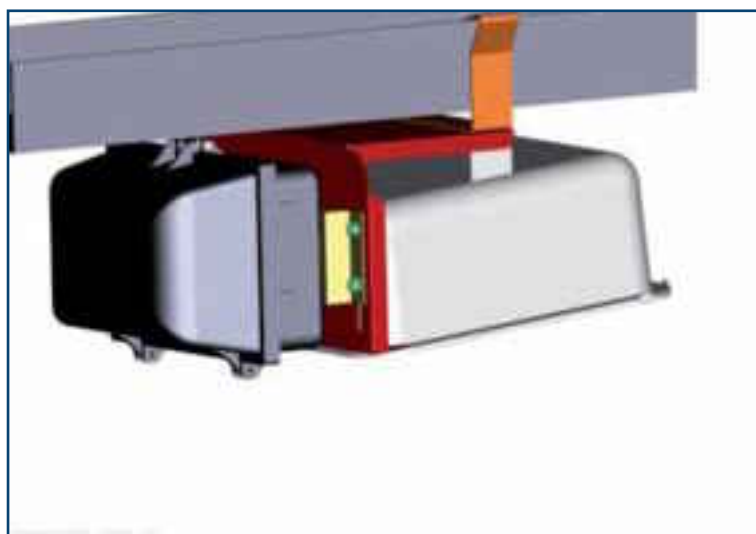
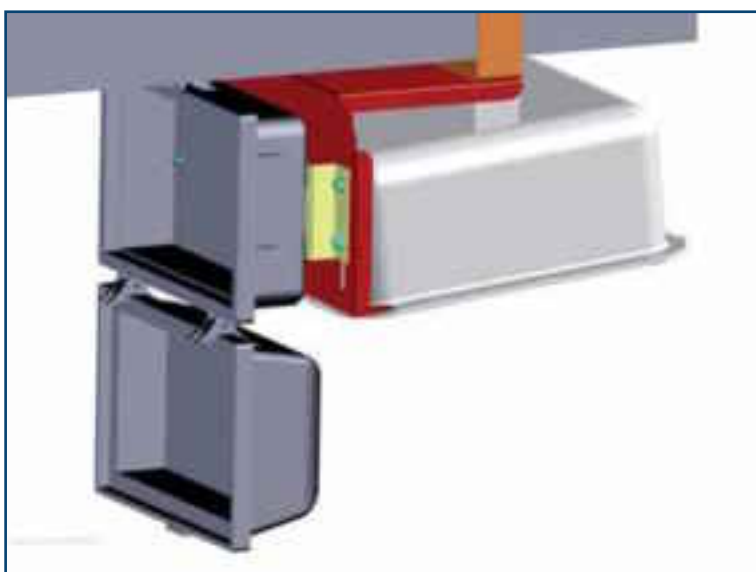



pag. 24



pag. 24



pag. 25

# TUNNEL S-A

Simmetrico - Asimmetrico

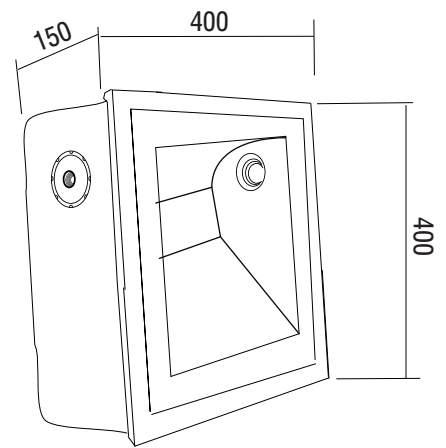

TUNNEL S-A



su richiesta

- Fusibile
- Cablaggio biregime
- IP66
- Cavo con spina stagna

on require

- Fuse
- Double regime wiring
- IP66
- Cable with sealed plug



Attacco canale in acciaio Inox  
Channel attachment in stainless steel

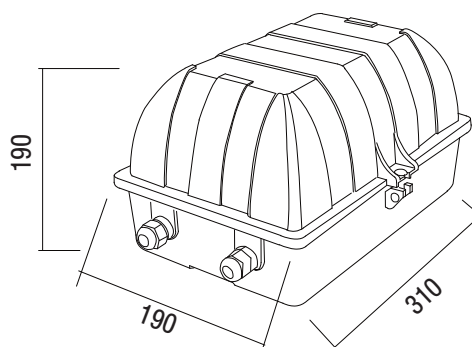

**classe 1 • class 1**

Codice	W	Lamp	p/lamp	Kg
BOX SAP701	70	SAP-T	E27	
BOX SAP1001	100	SAP-T	E40	
BOX SAP1501	150	SAP-T	E40	
BOX SAP2501	250	SAP-T	E40	
BOX SAP4001	400	SAP-T	E40	
BOX SAP6001	600	SAP-T	E40	

**classe 2 • class 2**

Codice	W	Lamp	p/lamp	Kg
BOX SAP702	70	SAP-T	E27	
BOX SAP1002	100	SAP-T	E40	
BOX SAP1502	150	SAP-T	E40	
BOX SAP2502	250	SAP-T	E40	
BOX SAP4002	400	SAP-T	E40	
BOX SAP6002	600	SAP-T	E40	



Cavo in uscita dal box con spina stagna 16A 250V.  
 Outgoing cable from box with sealed plug 16A 250V.



Linea e Design tradizionale  
Tecnicamente adeguato alle classiche richieste di mercato  
Diverse tipologie per coprire tutte le esigenze di progettazione

*Traditional Line and Design  
Technically suited for classic market requests  
Different typologies to cover all design requirements*

- Struttura:** Corpo realizzato in pressofusione di alluminio a basso contenuto di rame, con alettature di raffreddamento posteriori.
- Verniciatura:** A polveri epossipoliesteri colore nero, previo trattamento di fosfocromatazione del grezzo. Resistente agli agenti atmosferici ed alle nebbie saline.
- Staffa di fissaggio:** Realizzata in acciaio zincato e verniciata di colore nero. Sistema goniometrico di regolazione dell'inclinazione.
- Riflettore:** Disponibile in diverse tipologie illuminotecniche.
- Rifratore:** Vetro piano temperato spess. 5 mm. Resistente agli urti ed agli shock termici. Unito al corpo con cornice di alluminio incernierata ed avvitata al proiettore.
- Accesso:** Al vano ottico e morsettiera tramite portella posteriore in alluminio pressofuso incernierata ed avvitata al corpo.
- Guarnizioni:** Al silicone perimetrale al vano ottico ed alla portella posteriore, per garantire il grado IP.
- Viterie:** Esterne in acciaio inossidabile con sistema anticaduta, interne in acciaio zincato.
- Portalamпада:** In ceramica tipo E40 o K12s7.
- Gruppo di alimentazione:** esterno in box separato IP65
- Cavo:** A doppio isolamento al silicone tipo FG4G4
- Pressacavo:** In dotazione di M20 x 1,5.
- Componenti elettrici:** Di prima scelta e rigorosamente a marchio di qualità IMQ o ENEC.

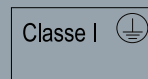

- Case:** Made of aluminium die-casting with low content of copper, with back finning of cooling.
- Coated:** With epoxy-polyester powder in black color, after phospho-chromate treatment of the raw product, resistant to atmospheric agent and to saline mist.
- Bracket:** Made of galvanized steel and painted of black color. With goniometric regulation system for aiming the projector.
- Reflector:** Available in a lot of lighting engineering typologies.
- Refractor:** Flat tempered glass, thick. 5 mm. Heat-proof and shock proof. Fixed to the body by the frame hinged and screwed made in aluminium.
- Entrance:** To the optical and connecting device compartment from the back door hinged and screwed at the body.
- Sealing gasket:** Made of silicone rubber around the optical and the back door compartments to guarantee the protection degree.
- Bolts and screws:** Outside made in stainless steel with antidrop system, Inside made in galvanized steel.
- Lampholder:** Made in ceramic, type E40 or K12s7.
- Control gear:** Outside in separate box IP65.
- Wire:** Double silicone insulation, type FG4G4.
- Cable clamp:** Included with M20 x 1,5.
- Electrical component:** First-rate supplier, absolutely with quality mark IMQ or ENEC

normative di riferimento

Marcatura CE  
EN 60598-1  
EN 60598-2-3  
Direttive Europee 2006/95/CE e 2004/108/CEE  
Gradi di protezione secondo EN 60529  
Norma sull'inquinamento luminoso UNI 10819  
Leggi Regionali in materia di inquinamento luminoso

reference standards

CE marking  
EN 60598-1  
EN 60598-2-3  
European Directives 2006/95/CE and 2004/108/CEE  
Protection rating pursuant to EN 60529  
Light pollution standard UNI 10819

cablaggi

Classe I: Con componenti elettrici montati su piastra in acciaio zincato, cablati e rifasati con cavo a doppio isolamento al silicone FG4G4. Carcassa e componenti attivi con impianto di messa a terra.

wiring

Class I: With electrical components assembled on galvanized steel plate, wired and phase corrected with double insulated cable in silicone FG4G4. Housing and active components with grounding system.

Vano portalamпада  
Attachment compartment



Vano porta accenditore  
Ignition compartment

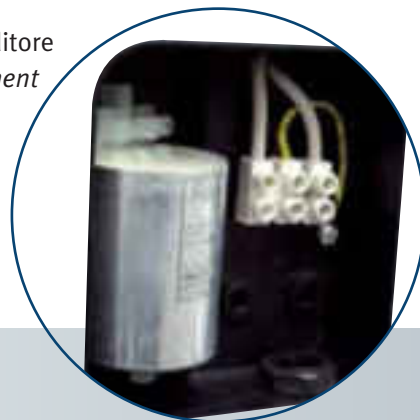

Sistema goniometrico di regolazione dell'inclinazione  
Protractor system for adjustment of inclination

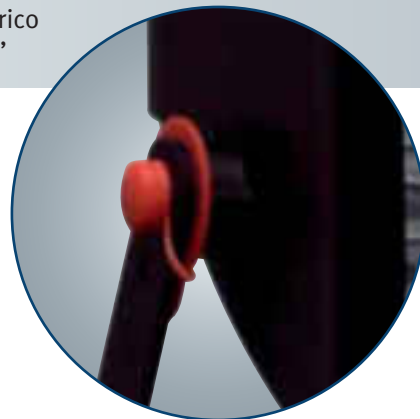

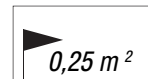
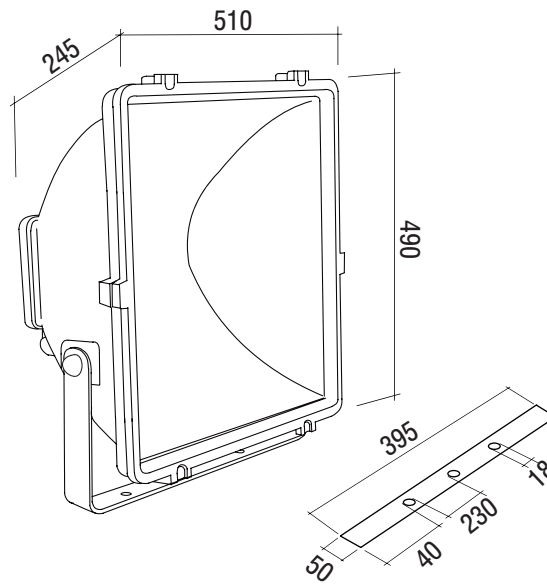

classe 1 • c/acc

Codice	W	Lamp	p/lamp	Kg
ASSOKD/KCJM10001A	1000	JM	K12s7	13
ASSOKD/KCJM20001A	2000	JM	K12s7	13
ASSOKD/KCSAP10001A	1000	SAP	K12s7	13

classe 1 • s/acc

Codice	W	Lamp	p/lamp	Kg
ASSOKD/KCJM10001	1000	JM	K12s7	13
ASSOKD/KCJM20001	2000	JM	K12s7	13
ASSOKD/KCSAP10001	1000	SAP	K12s7	13

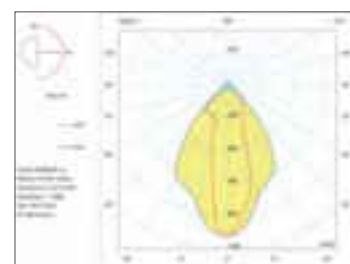

ASSOK 2000JM



Linea e Design tradizionale  
Tecnicamente adeguato alle classiche richieste di mercato  
Diverse tipologie per coprire tutte le esigenze di progettazione

*Traditional Line and Design  
Technically suited for classic market requests  
Different typologies to cover all design requirements*

- Struttura: Corpo realizzato in pressofusione di alluminio a basso contenuto di rame, con alettature di raffreddamento posteriori.
- Verniciatura: A polveri epossipoliesteri colore nero, previo trattamento di fosfocromatazione del grezzo. Resistente agli agenti atmosferici ed alle nebbie saline.
- Staffa di fissaggio: Realizzata in acciaio zincato e verniciata di colore nero. Sistema goniometrico di regolazione dell'inclinazione.
- Riflettore: Disponibile in diverse tipologie illuminotecniche.
- Vetro: Piano temperato spess. 5 mm. Resistente agli urti ed agli shock termici. Unito al corpo con cornice di alluminio incernierata ed avvitata al proiettore.
- Accesso: Al vano ottico e morsettiera tramite portella posteriore in alluminio pressofuso incernierata ed avvitata al corpo.
- Guarnizioni: Al silicone perimetrale al vano ottico ed alla portella posteriore, per garantire il grado IP.
- Viterie: Esterne in acciaio inossidabile con sistema anticaduta, interne in acciaio zincato.
- Portalamпада: In ceramica tipo E40 o K12s7.
- Gruppo di alimentazione: Esterno in box separato IP65
- Cavo: A doppio isolamento al silicone tipo FG4G4
- Pressacavo: in dotazione di M20 x 1,5.
- Componenti elettrici: Di prima scelta e rigorosamente a marchio di qualità IMQ, ENEC o equivalenti.

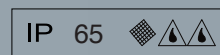
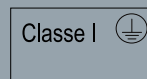

- Structure: Body made in die cast low copper content aluminium, with rear cooling fins*
- Painting: Black polyester-epoxy powder, by means of phospho-chromate treatment of the raw material.*
- Holding bracket: Made in galvanized steel and painted black. Adjustment of inclination with protractor system.*
- Reflector: Available in different illumination-technical types.*
- Glass: Tempered surface 5 mm thick. Resistant to blows and thermal shocks. Attached to the body with hinged aluminium frame screwed on to the floodlight.*
- Access: To optical and terminal boards through rear door in hinged die cast aluminium screwed on to the body.*
- Seals: In silicone around the optical area and the rear door, to guarantee IP grade.*
- Screws: External in stainless steel with fall-protection system, internal in galvanized steel.*
- Light holder: Ceramic, type E40 or K12s7.*
- Power supply group: external in separate IP65 box*
- Cable: double insulation in silicone type FG4G4*
- Cable clamp: included with M20 x 1,5.*
- Electrical components: first quality and strictly with IMQ, ENEC or equivalent quality-marking.*

normative di riferimento

Marcatura CE  
EN 60598-1  
EN 60598-2-3  
Direttive Europee 2006/95/CE e 2004/108/CEE  
Gradi di protezione secondo EN 60529  
Norma sull'inquinamento luminoso UNI 10819  
Leggi Regionali in materia di inquinamento luminoso

reference standards

CE marking  
EN 60598-1  
EN 60598-2-3  
European Directives 2006/95/CE and 2004/108/CEE  
Protection rating pursuant to EN 60529  
Light pollution standard UNI 10819

cablaggi

Classe I: Con componenti elettrici montati su piastra in acciaio zincato, cablati e rifasati con cavo a doppio isolamento al silicone FG4G4. Carcassa e componenti attivi con impianto di messa a terra.

wiring

*Class I: With electrical components assembled on galvanized steel plate, wired and phase corrected with double insulated cable in silicone FG4G4. Housing and active components with grounding system.*

Applicazioni

- Piccoli e grandi impianti sportivi
- Campi da tennis, Calcio a 5
- Palestre
- Aree industriali
- Aree commerciali e parcheggi
- Parchi e monumenti
- Illuminazione di facciate
- Svincoli stradali ed autostradali
- Rotatorie
- Porti, Aeroporti
- Incroci stradali

Application

- Small and large sports centers
- Tennis courts, 5-person soccer
- Gyms
- Industrial areas
- Business centers and parking lots
- Parks and monuments
- Facade illumination
- Street and highway exits
- Rotary circles
- Ports, Airports
- Street intersections

Installazione BIG - Olbia



Installazione BIG - Modena



Installazione BIG-ED - San Michele



Installazione BIG-ED - Campo da Calcio a Trento



Installazione BIG-ED - Campo da Calcio a Sassari



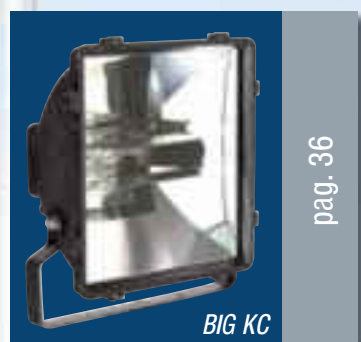
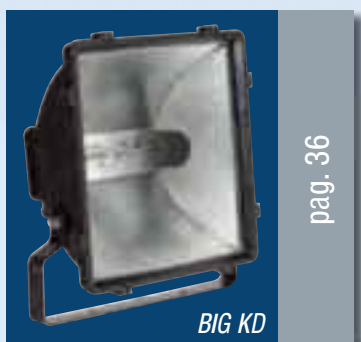
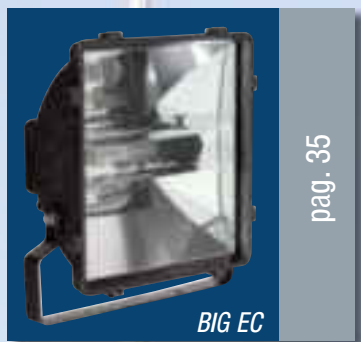
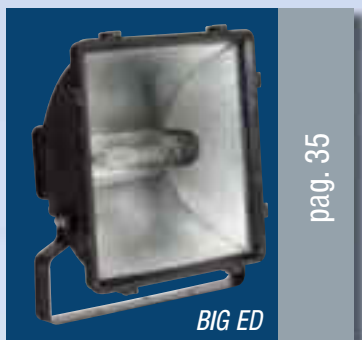

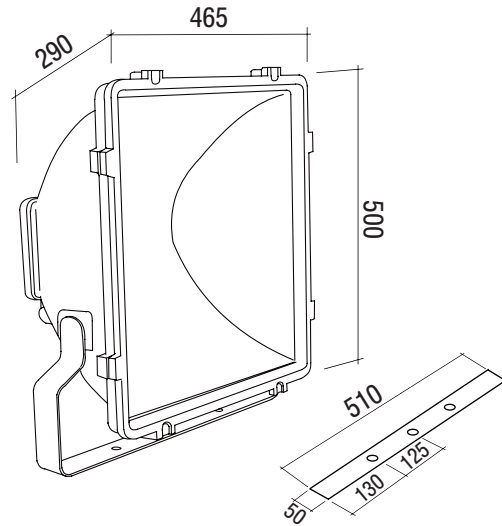

CABLAGGIO CON BOX (vedi pag. 48)  
WIRING WITH BOX (see page 48)

0,23 m<sup>2</sup>

classe 1 • class 1

Codice	W	Lamp	p/lamp	Kg
BIGED/ECSAP10001	1000	SAP-T	E40	13
BIGED/ECJM10001	1000	JM-T	E40	13
BIGED/ECJM20001	2000	JM-T	E40	13

Vano portalampana  
Attachment compartment



Sistema goniometrico di regolazione dell'inclinazione  
Protractor system for adjustment of inclination



su richiesta

- Fusibile
- Colori RAL

on require

- Fuse
- RAL colors

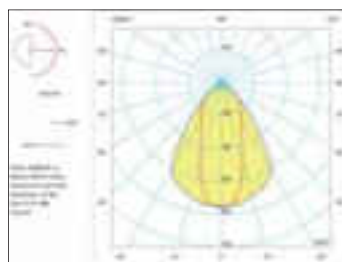

BIG ED 1000JM

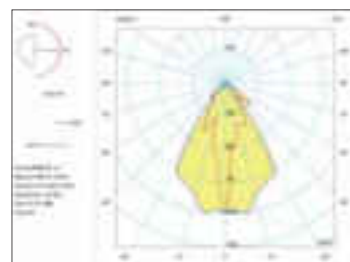

BIG EC 1000JM

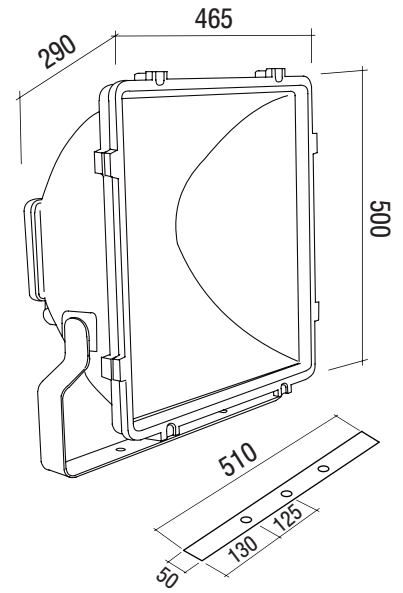

CABLAGGIO CON BOX (vedi pag. 48)  
WIRING WITH BOX (see page 48)

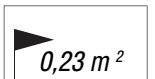

BIG-KD/KC

classe 1 • class 1

Codice	W	Lamp	p/lamp	Kg
BIGKD/KCSAP10001	1000	SAP	K12s7	13
BIGKD/KCJM10001	1000	JM	K12s7	13
BIGKD/KCJM20001	2000	JM	K12s7	13

Sistema goniometrico di regolazione dell'inclinazione  
*Protractor system for adjustment of inclination*



su richiesta

- Fusibile
- Colori RAL

on require

- Fuse
- RAL colors



Portalampana K 12s7 a cavi  
*K12s7 double attachment*

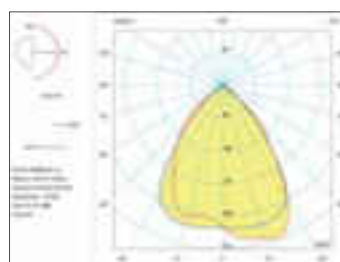

BIG KD 2000 JM

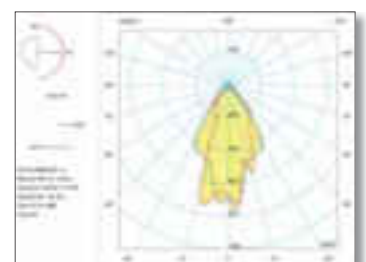

BIG KC 2000 JM

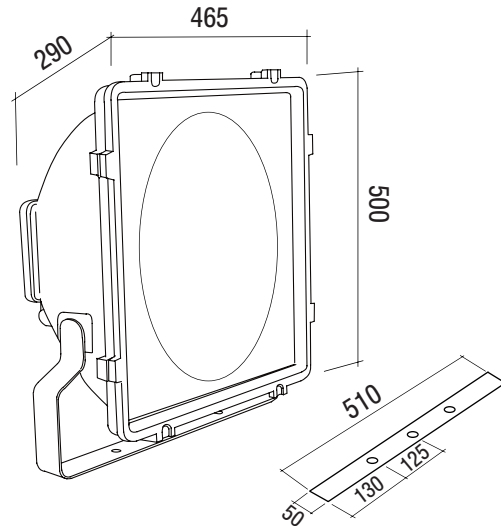

CABLAGGIO CON BOX (vedi pag. 48)  
 WIRING WITH BOX (see page 48)

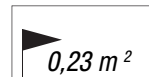

classe 1 • class 1

Codice	W	Lamp	p/lamp	Kg
BIGPCJM10001	1000	JM - S	K12s7	13
BIGPCJM20001	2000	JM - S	K12s7	13

Sistema goniometrico di regolazione dell'inclinazione  
 Protractor system for adjustment of inclination

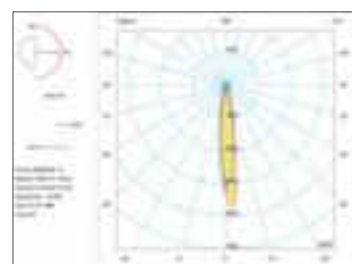

BIG PC 2000 JM

# DOUBLE

Proiettore Stradale IP65





Linea e Design tradizionale  
Tecnicamente adeguato alle classiche richieste di mercato  
Diverse tipologie per coprire tutte le esigenze di progettazione

*Traditional Line and Design  
Technically suited for classic market requests  
Different typologies to cover all design requirements*

- Struttura:** Corpo e cornice realizzati in lastra di alluminio sp. 2 mm saldata, verniciato mediante polveri epossipoliestere di colore nero previo trattamento di fosfocromatazione del grezzo, resistente agli agenti atmosferici ed alle nebbie saline.
- Staffa di fissaggio:** Realizzata in alluminio sp. 5 mm. con sistema goniometrico di regolazione dell' inclinazione.
- Riflettore:** ASIMMETRICO 60° ad emissione diffondente, realizzato in alluminio martellato purissimo 99,85% brillantato ed ossidato anodicamente.
- Rifrattore:** Vetro piano temperato spess. 5mm, fissato al corpo con quattro angolari e con collante al silicone antimuffa per tutto il perimetro a garantire la tenuta IP. Resistente agli urti ed agli shock termici.
- Viterie:** Esterne ed interne in acciaio inossidabile.
- Portalampada:** In ceramica tipo E40.
- Supporto portalampada:** A tappo realizzato in materiale plastico nylon caricato del 30% di fibra di vetro, fissato sulla fiancata del proiettore e asportabile con 1/3 di giro senza l'utilizzo di utensili, per una facile manutenzione alla lampada. Sistema di regolazione del fuoco lampada.
- Gruppo di alimentazione:** Esterno in BOX di alimentazione
- Dotazioni:** PG13.5 antistrappo in ottone nichelato.  
Cavo elettrico 2x1,5mmq tipo FTG10(O)M1 per il collegamento dalla cassetta di alimentazione al portalampada del proiettore.
- Componenti elettrici:** Di prima scelta e rigorosamente a marchio di qualità IMQ o ENEC



CE

Classe I IP 65  

- Structure:** Casing and frame made of 2-mm thick aluminium sheet, welded with square wave and painted with black epoxy-polyester powder paint, after phospho-chromate treatment of coarse piece, resistant to atmospheric agents and salt mist.
- Holding bracket:** Made of 5-mm thick aluminium with goniometric adjustment system of the tilt angle.
- Reflector:** ASYMMETRIC 60° with diffusing emission, made of hammered highly pure aluminium 99.85% shined and anodically oxidised.
- Refractor:** Flat 5-mm thick hardened glass, secured to the casing with four angle brackets and mould-proof silicone adhesive around the whole perimeter to guarantee IP seal. Resistant to impact and thermal shock.
- Screws and bolts:** External and internal, stainless steel.
- Lamp holder:** Ceramic, type E40.
- Lamp holder support:** Cap type made of nylon plastic material, reinforced with 30% of fibreglass, for easy lamp maintenance. Lamp focus adjustment system.
- Power supply:** External, in power supply BOX.
- Equipment supplied:** PG13.5 tear-proof in nickel-plated brass.
- Electrical cable** 2x1.5 sq mm type FTG10(O)M1 for connecting from power supply box to lamp holder of projector.
- Electrical components:** Top quality and strictly with IMQ or ENEC quality mark.

normative di riferimento

Marcatura CE  
EN 60598-1  
EN 60598-2-3  
Direttive Europee 2006/95/CE e 2004/108/CEE  
Gradi di protezione secondo EN 60529  
Norma sull'inquinamento luminoso UNI10819  
Leggi Regionali in materia di inquinamento luminoso

reference standards

CE marking  
EN 60598-1  
EN 60598-2-3  
European Directives 2006/95/CE and 2004/108/CEE  
Protection rating pursuant to EN 60529  
Light pollution standard UNI 10819

cablaggi

Classe I: Con componenti elettrici montati su piastra in acciaio zincato, cablati e rifasati con cavo a doppio isolamento al silicone FG4G4. Carcassa e componenti attivi con impianto di messa a terra.

wiring

*Class I: With electrical components assembled on galvanized steel plate, wired and phase corrected with double insulated cable in silicone FG4G4. Housing and active components with grounding system.*

Installazione DOUBLE - Ravenna



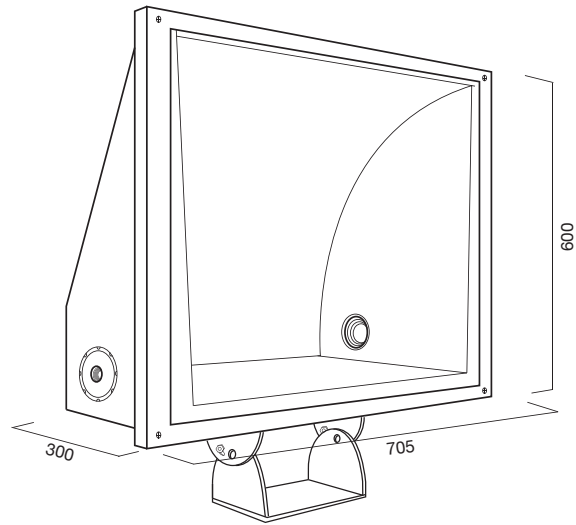

0,21 m<sup>2</sup>

classe 1 • class 1

Codice	W	Lamp	p/lamp	Kg
DOUBLESAP4001	2x400	SAP-T	E40	13
DOUBLESAP6001	2x600	SAP-T	E40	13
DOUBLEJM4001	2x400	JM-T	E40	13

CABLAGGIO CON BOX (vedi pag. 48)  
WIRING WITH BOX (see page 48)



Portalampada E40  
E40 attachment





Linea e Design tradizionale  
Tecnicamente adeguato alle classiche richieste di mercato  
Diverse tipologie per coprire tutte le esigenze di progettazione

*Traditional Line and Design  
Technically suited for classic market requests  
Different typologies to cover all design requirements*

- Struttura: Corpo e coperchio in alluminio pressofuso con alettature di raffreddamento verniciate nere. Fissaggio tramite gancio a occhiello passo M8.
- Riflettore: LISCIO o PRISMATICO ad emissione diffondente o concentrante, realizzato in alluminio martellato purissimo 99,85% brillantato ed ossidato anodicamente.
- Rifrattore: Vetro piano temperato spess. 5 mm, fissato al corpo con quattro ganci con possibilità di aggiunta di una gabbia di protezione in piatto di acciaio. Resistente agli urti ed agli shock termici.
- Viterie: Esterne in acciaio inossidabile.
- Portalampada: In ceramica tipo E40.
- Gruppo di alimentazione: Incluso nel BOX di alimentazione sovrastante.
- Dotazioni: PG11 per cavo tripolare sez. 1,5 mm.
- Componenti elettrici: Di prima scelta e rigorosamente a marchio di qualità IMQ o ENEC.



CE

Classe I	
Classe II	

IP 65		
-------	--	--

- Structure: Casing and cover made of die-cast aluminium with cooling fins painted black.*
- Fixture: eyelet hook, pitch M8.*
- Reflector: SMOOTH or PRISMATIC with diffusing or concentrated emission, made of hammered highly pure aluminium 99,85% shined and anodically oxidized.*
- Refractor: Flat 5-mm thick hardened glass, secured to the casing with four hooks with possibility to add a steel plate protection cage. Resistant to impact and thermal shock.*
- Screws and bolts: External, stainless steel*
- Lamp holder: Ceramic, type E40.*
- Power supply unit: included in power supply BOX above.*
- Equipment supplied: PG11 for three-pole cable, cross section 1.5 mm.*
- Electrical components: Top quality and strictly with IMQ or ENEC quality mark.*

**normative di riferimento**

Marcatura CE  
EN 60598-1  
EN 60598-2-3  
Direttive Europee 2006/95/CE e 2004/108/CEE  
Gradi di protezione secondo EN 60529  
Norma sull'inquinamento luminoso UNI 10819  
Leggi Regionali in materia di inquinamento luminoso

**reference standards**

CE marking  
EN 60598-1  
EN 60598-2-3  
European Directives 2006/95/CE and 2004/108/CEE  
Protection rating pursuant to EN 60529  
Light pollution standard UNI 10819

**cablaggi**

Classe I: Con componenti elettrici montati su piastra in acciaio zincato, cablati e rifasati con cavo a doppio isolamento al silicone FG4G4. Carcassa e componenti attivi con impianto di messa a terra.

Classe II: Gruppo di alimentazione montato su piastra isolata con sezionatore di linea per classe II. Collegamenti alla lampada con cavo a doppio isolamento al silicone FG4G4.

**wiring**

*Class I: With electrical components assembled on galvanized steel plate, wired and phase corrected with double insulated cable in silicone FG4G4. Housing and active components with grounding system.*

*Class II: Compact power supply group with resin reactor and other integrated components in a case in class II-approved insulating material. Connections to the light with double insulated cable in silicone FG4G4.*

Box porta cablaggio  
*Box with wiring*



Connettore  
*Connector*



Particolare portalampana  
*Attachment detail*





classe 1 • class 1

Codice	W	Lamp	p/lamp	Kg
INDUSTRIALCSAP2501	250	SAP-T	E40	7
INDUSTRIALCSAP4001	400	SAP-T	E40	8
INDUSTRIALCJM2501	250	JM-T	E40	5,5
INDUSTRIALCJM4001	400	JM-T	E40	6,5
INDUSTRIALDSAP2501	250	SAP-T	E40	7
INDUSTRIALDSAP4001	400	SAP-T	E40	8
INDUSTRIALDJM2501	250	JM-T	E40	5,5
INDUSTRIALDJM4001	400	JM-T	E40	6,5

classe 2 • class 2

Codice	W	Lamp	p/lamp	Kg
INDUSTRIALCSAP2502S	250	SAP-T	E40	7
INDUSTRIALCSAP4002S	400	SAP-T	E40	8
INDUSTRIALCJM2502S	250	JM-T	E40	5,5
INDUSTRIALCJM4002S	400	JM-T	E40	6,5
INDUSTRIALDSAP2502S	250	SAP-T	E40	7
INDUSTRIALDSAP4002S	400	SAP-T	E40	8
INDUSTRIALDJM2502S	250	JM-T	E40	5,5
INDUSTRIALDJM4002S	400	JM-T	E40	6,5

# GRUPPI DI ALIMENTAZIONE



Gruppi di Alimentazione



- Struttura: Corpo realizzato in pressofusione di alluminio a basso contenuto di rame.  
 Coperchio: incernierato alla base e bloccato con vite in acciaio inossidabile.  
 Verniciatura: A polveri epossipoliesteri colore nero, previo trattamento di fosfocromatazione del grezzo. Resistente agli agenti atmosferici ed alle nebbie saline.  
 Staffa di fissaggio: Realizzata in acciaio zincato e verniciata di colore nero.  
 Guarnizioni: Al silicone per garantire il grado IP.  
 Viterie: Interne ed esterne in acciaio inossidabile.  
 Componenti elettrici: Di prima scelta e rigorosamente a marchio di qualità IMQ o ENEC. Cablati e rifasati su piastra in acciaio zincato. Cavo a doppio isolamento al silicone FG4G4.  
 Pressacavi: In dotazione M20 x 1,5.



CE

Classe I   
 Classe II 

IP 65 

- Structure: Body made in die cast low copper content aluminium, with rear cooling fins*  
*Cover: hinged at the base and blocked with screws in stainless steel.*  
*Painting: Black polyester-epoxy powder, by means of phospho-chromate treatment of the raw material.*  
*Holding bracket: Made in galvanized steel and painted black.*  
*Seals: In silicone to guarantee IP grade.*  
*Screws: Internal and external in stainless steel*  
*Electrical components: first quality and strictly with IMQ or ENEC quality-marking. Wired and phase corrected on galvanized steel plate. Double insulated cable in silicone FG4G4.*  
*Cable clamps: Included with M20 x 1,5.*

# BOX65

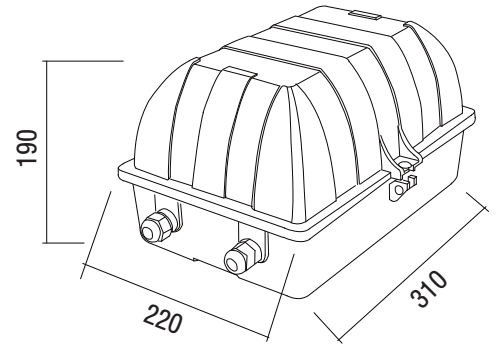

Box aperto con piastra portacablaggio alloggiata al suo interno.  
*Open box with wiring holding plate lodged inside.*



Particolare della staffa di fissaggio  
*Detail of the holding bracket*

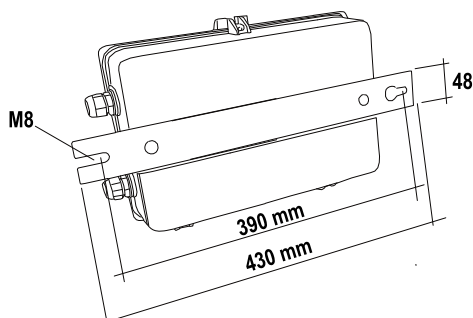

classe 1 • c/acc

Codice	W	Lamp	Corr	Kg
BOX65SAP2501A	250 3A	SAP	230	5,5
BOX65SAP4001A	400 4,4A	SAP	230	6,5
BOX65SAP6001A	600 6,2A	SAP	230	10
BOX65SAP10001A	1000 10,3A	SAP	230	13
BOX65JM250P1A	250 2,15A	JM	230	5
BOX65JM400P1A	400 3,3A	JM	230	6
BOX65JM1000P1A	1000 8,2A	JM	230	13
BOX65JM1000O1A	1000 9,5A	JM	230	13
BOX65JM2000O1A	2000 10,3A	JM	380	18
BOX65JM2000P1A	2000 8,8A	JM	380	18
BOX65JM200021A	2000 16,5A	JM	230	

classe 1 • s/acc

Codice	W	Lamp	Corr	Kg
BOX65SAP2501	250 3A	SAP	230	5,5
BOX65SAP4001	400 4,4A	SAP	230	6,5
BOX65SAP6001	600 6,2A	SAP	230	10
BOX65SAP10001	1000 10,3A	SAP	230	13
BOX65JM250P1	250 2,15A	JM	230	5
BOX65JM400P1	400 3,3A	JM	230	6
BOX65JM1000P1	1000 8,2A	JM	230	13
BOX65JM1000O1	1000 9,5A	JM	230	13
BOX65JM2000O1	2000 10,3A	JM	380	18
BOX65JM2000P1	2000 8,8A	JM	380	18
BOX65JM200021	2000 16,5A	JM	230	

**su richiesta**

- Fusibile
- Cablaggio biregime
- Colori RAL

**on require**

- Fuse
- Double regime wiring
- RAL colors